



Standard Test Method for Shear Testing of Calcium Phosphate Coatings and Metallic Coatings¹

This standard is issued under the fixed designation F 1044; the number immediately following the designation indicates the year of original adoption or, in the case of revision, the year of last revision. A number in parentheses indicates the year of last reapproval. A superscript epsilon (ε) indicates an editorial change since the last revision or reapproval.

1. Scope

1.1 This test method covers shear testing of continuous calcium phosphate coatings and metallic coatings adhering to dense metal substrates at ambient temperatures. It assesses the degree of adhesion of coatings to substrates, or the internal cohesion of a coating in shear, parallel to the surface plane.

1.2 The values stated in SI units are to be regarded as the standard. The values given in parentheses are for information only.

1.3 *This standard may involve hazardous materials, operations, and equipment. This standard does not purport to address all of the safety concerns, if any, associated with its use. It is the responsibility of the user of this standard to establish appropriate safety and health practices and determine the applicability of regulatory limitations prior to use.*

2. Referenced Documents

2.1 *ASTM Standards:*²

E 4 Practices for Force Verification of Testing Machines

E 6 Terminology Relating to Methods of Mechanical Testing

E 8 Test Methods for Tension Testing of Metallic Materials

3. Terminology

3.1 *Definitions*—Terminology **E 6** shall be considered as applying to the terms used in this test method.

4. Summary of Test Method

4.1 *Shear Method for Calcium Phosphate or Metallic Coatings:*

4.1.1 This test method consists of subjecting a specimen assembly composed of one coated and one uncoated component to a shear load. The components to be tested may be

bonded together directly by thermomechanical means (for example, sintering or diffusion bonding) or may be bonded together by use of a polymeric adhesive. The adhesive may be in film form or bulk form, but it must have a minimum bulk shear strength of 34.5 MPa (5000 psi) or as great as the minimum required adhesion or cohesion strength of the coating, whichever is greater.

4.1.2 The shear load must be applied parallel to the plane of the coating utilizing a tensile machine, which is capable of determining the maximum strength of the coating or coating attachment to the substrate interface.

4.2 *Shear Method for Metallic Coatings Only*—The lap shear method consists of subjecting a porous coated area to single shear loading, generally utilizing suitable polymeric adhesive or bone cement adhesive and test jig in a tension machine, and determining the maximum shear stress required to obtain separation (that is, the shear strength of the coating/substrate bond or shear strength of the coating).

5. Significance and Use

5.1 The shear test method is recommended for shear testing of calcium phosphate and metallic/substrate combinations and can provide information on the adhesive or cohesive strength of coatings under a uniaxial shear stress.

5.2 The test method may be useful for comparative evaluation of adhesive or cohesive strengths of a variety of types of coatings. Information developed using this test method may be useful for certain quality control and design purposes.

5.3 The test method should not be considered to provide an intrinsic values for utilization directly in making calculations such as determining the ability of a coating to withstand specified environmental stresses.

5.4 Processing variables, such as substrate preparation prior to coating, surface texture, coating technique variables or post-coating heat treatment, or heat may introduce a significant effect on the results of the shear test. The specimen being evaluated must be representative of the actual end-use coating.

6. Apparatus

6.1 *Testing Machines*—Machines used for testing shall conform to the requirements of Practices **E 4**. The loads used in determining shear strength and yield strength shall be within

¹ This test method is under the jurisdiction of ASTM Committee F04 on Medical and Surgical Materials and Devices and is the direct responsibility of Subcommittee F04.15 on Material Test Methods.

Current edition approved April 1, 2005. Published April 2005. Originally approved in 1999. Last previous edition approved in 1999 as F 1044 – 99.

² For referenced ASTM standards, visit the ASTM website, www.astm.org, or contact ASTM Customer Service at service@astm.org. For *Annual Book of ASTM Standards* volume information, refer to the standard's Document Summary page on the ASTM website.

the loading range of the testing machine as defined in Practices E 4. See also Test Methods E 8.

6.2 Gripping Devices:

6.2.1 General—Various types of grips may be used to transmit the load applied to the specimens by the testing machine. To ensure axial shear stress, it is important that the specimen axis coincide with the centerline of the heads of the testing machine and that the coating test plane be parallel to the axial load. Any departure from this requirement (that is, any eccentric loading) will introduce bending stresses that are not included in the usual stress calculation (force/cross-sectional area).

6.2.2 Aligned Interface Method for Calcium Phosphate or Metallic Coatings:

6.2.2.1 A drawing of a typical gripping device for the test assembly is shown in Fig. 1.

6.2.2.2 A drawing of the adapter to mate the shear fixture to the tensile machine is shown in Fig. 2.

6.2.2.3 A schematic of the test assembly is shown in Fig. 3.

6.2.3 Lap Shear Method for Metallic Coatings Only:

6.2.3.1 Lap Shear Testing Bonding Fixture—A bonding fixture of the type shown in Fig. 4 or equivalent shall be designed and machined with sufficient precision to minimize movement of the specimen during curing of the adhesive. Some coatings, such as porous fiber metal coatings, may be bonded by sintering without the use of this fixture.

6.2.3.2 Lap Shear Test Loading Grips—A loading jig of the type shown in Fig. 5 or equivalent shall be used. It shall be made of hardened steel having a hardness of not less than Rockwell C60. To minimize the possible effect of distortion of the device under load, fitted and machined steel bolts may be used to hold the components together. The interfaces between the tongue and clevises shall be smooth.

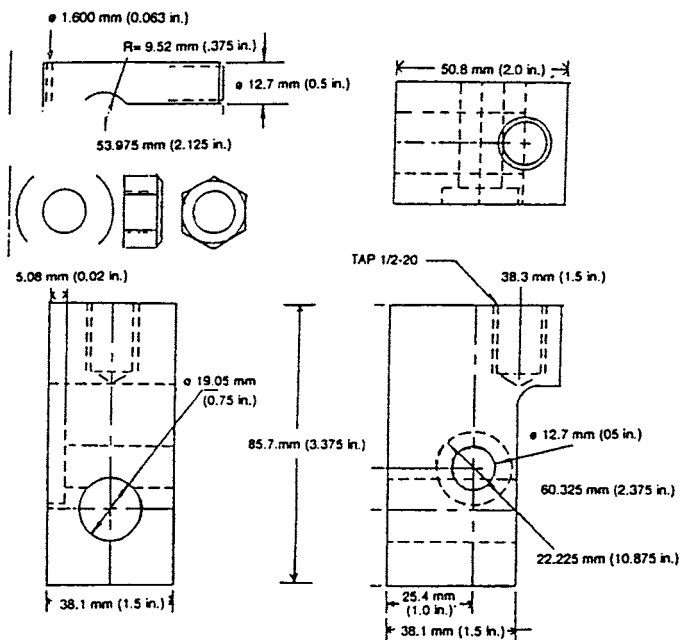

FIG. 1 Gripping Device for Shear Testing

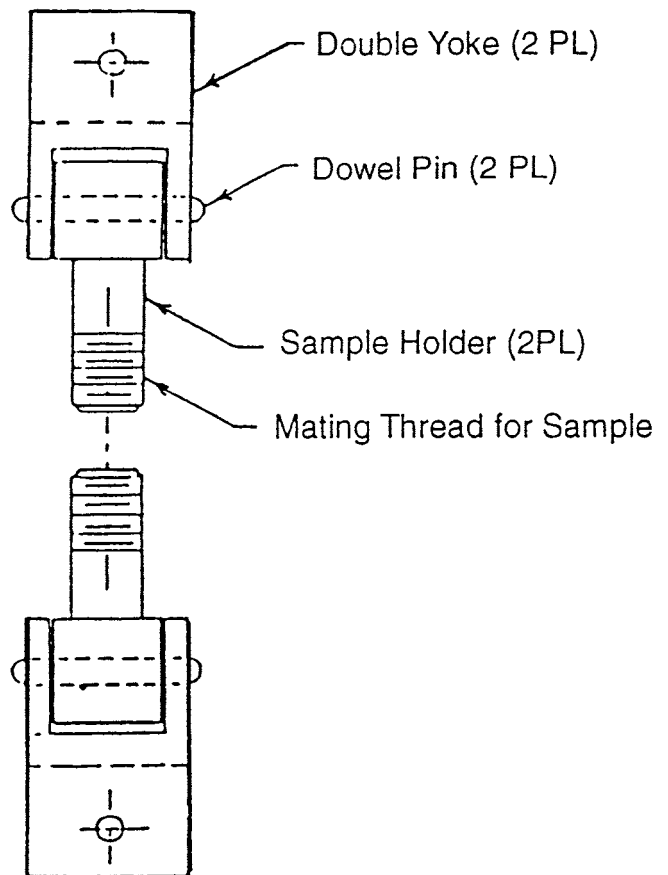

FIG. 2 Adapter to Mate the Gripping Device to the Tensile Machine

7. Adhesive Bonding Materials

7.1 Adhesive Bonding Agent—A polymeric adhesive bonding agent in film form, or filled viscous adhesive cement, when used, shall be identified and shall meet the following requirements:

7.1.1 The bonding agent shall be capable of bonding the coating on the test specimen components with an adhesive shear strength that is at least 34.5 MPa (5000 psi) or as great as the minimum required adhesion or cohesion strength of the coating, whichever is greater.

7.1.2 In instances where porosity extends to the coating/substrate interface, the bonding agent shall be sufficiently viscous and application to the coating sufficiently careful to assure that it will not penetrate through the coating to the substrate. The FM 1000 Adhesive Film³ with a thickness of 0.25 mm (0.01 in.) has proven satisfactory for this test.

7.1.3 If a material other than FM 1000 is used, or the condition of the FM 1000 is unknown, it must be tested to establish its equivalence to fresh FM 1000. Testing should be performed without the presence of the calcium phosphate coating to establish the performance of the adhesive.

³ The sole source of supply of the apparatus known to the committee at this time is Cytec Engineered Materials, Inc., 1300 Revolution St., Havre de Grace, MD 21078. If you are aware of alternative suppliers, please provide this information to ASTM International Headquarters. Your comments will receive careful consideration at a meeting of the responsible technical committee,¹ which you may attend.